

# SNAKE-ARM LAMP

## Instruction Manual

**DANRAY Products** LLC  
MACHINE SAFEGUARDS AND ACCESSORIES



Snake-arm lamps from Danray Products LLC will light the point of operation of machines or work areas where additional light is required. A bright, conical metal reflector directs the light to where it is needed. Each lamp uses a 100-watt-maximum standard incandescent or equivalent (CFL, LED) screw-in lightbulb (not included). An innovative, finned-aluminum heat sink keeps the on/off toggle switch cool for a long switch life. The heavy-duty snake arms are made of spring steel covered with vinyl to protect them from grease, oil, and contaminants that would weaken their holding ability (unlike other inferior gooseneck or flexible arms found on the market). They offer practically unlimited adjustment possibilities and long-term holding power.

All snake-arm lamps are UL Listed to United States and Canadian safety standards. Each lamp has a 6' oil-resistant power cord with a 120-volt grounded plug. The SJTO 18/3 thermoplastic cord has three 18-gauge wires, a NEMA 5-15 plug, and is rated up to 105°C (221°F). Each lampshade is made of high-impact polycarbonate that is resistant to chipping, denting, and cracking. The lampshade has a double wall that keeps the outer wall from getting too hot; this allows adjustment of the lampshade while in use, even after the lamp has been on for hours!

Three different mounting bases are available: direct-mount, C-clamp, and magnetic. The direct-mount base can be fastened to most any flat surface at least 2" x 1" with two included ¼" fasteners. The C-clamp base can be mounted to a table, bench, or any surface up to 1⅞" thick. The magnetic base has a ¾"-diameter magnet with 100 pounds of holding force. (Note: When applying a magnetic base, the mounting surface must be flat, ferrous metal thick enough and with a high percentage of iron for good holding power.)

Optional accessories include a wire guard that can be snapped onto the front rim of the lampshade to protect the lightbulb, two magnifier attachments that can mount directly to the lampshade, and two right-angle mounting brackets. Both magnifier attachments have a 2" x 4", 2-power glass lens, but one also includes a 1"-diameter, 4-power meniscus inset located near the right edge of the lens. Each magnifier attachment comes with a cover that slides over the lens to protect it when not in use. (Note: A wire guard cannot be used in conjunction with a magnifier attachment.) Based on the available mounting location(s), a horizontal or vertical right-angle mounting bracket can be used with the direct-mount base to help position the lamp where needed.

Part No.	Description
LMP-18D	Lamp With 18" Snake Arm and Direct-Mount Base
LMP-24D	Lamp With 24" Snake Arm and Direct-Mount Base
LMP-18C	Lamp With 18" Snake Arm and C-Clamp Base
LMP-24C	Lamp With 24" Snake Arm and C-Clamp Base
LMP-18M	Lamp With 18" Snake Arm and Magnetic Base
LMP-24M	Lamp With 24" Snake Arm and Magnetic Base

Optional Accessories	
LMP-WG	Wire Guard That Snaps Onto the Lampshade to Protect the Bulb
LMP-MA	Magnifier Attachment With 2" x 4", 2-Power Glass Lens
LMP-MAD	Magnifier Attachment With 2" x 4", 2-Power Glass Lens and 1"-Diameter, 4-Power Inset
BKT-150	Horizontal Right-Angle Mounting Bracket
BKT-160	Vertical Right-Angle Mounting Bracket

TF 1.866.482.6807 / P 815.262.6667 | 973 Featherstone Road, Unit 115, Rockford, Illinois 61107 | [www.danrayproducts.com](http://www.danrayproducts.com) / [service@danrayproducts.com](mailto:service@danrayproducts.com)

**DANRAY Products** LLC  
MACHINE SAFEGUARDS AND ACCESSORIES

Copyright © 2012 by Danray Products LLC. All rights reserved.

Manual No. MAN-001



Thank you for purchasing a Danray Products snake-arm lamp. This versatile, durable, and adjustable lamp can be used in many applications. This quality-made, heavy-duty lamp is proudly made in the United States of America.

#### Lamp With a Direct-Mount Base

If you have a lamp with a direct-mount base, the box will contain a bag of fasteners that includes two ¼"-20 x ¾" socket-head cap screws, two ¼"-20 hex nylon-insert locknuts, and two No. 12 pan-head Phillips x 1" zinc-plated sheet-metal screws. The socket-head cap screws use a ⅜" hex key and the pan-head sheet-metal screws use a Phillips No. 3 drive tip. If the lamp will be mounted directly to a thick, metal mounting surface (at least ⅜" thick), the direct-mount base can be mounted by drilling two holes and then tapping them with a ¼"-20 tap. A No. 7 drill (0.2010" diameter) is normally used to drill the holes before

tapping them. (Consult an industrial supplier if you have questions about drilling and tapping holes or if you need these items.)



**If you are mounting the lamp to a surface that has internal components or liquid, be careful not to drill through this surface because it may cause electric shock, leakage, or damage.**

If the lamp will be mounted to a thin surface (less than ⅜" thick), two ⅝" clearance holes can be drilled and you can use the socket-head cap screws with the included locknuts. If the lamp is being attached to sheet metal, wood, or another surface, the two sheet-metal screws can be used. The mounting template at the top-right corner of this page can be used for spotting the mounting holes.

#### Optional Horizontal or Vertical Right-Angle Mounting Bracket

Based on the available mounting location(s), a horizontal or vertical right-angle mounting bracket can be used with the direct-mount base to help position the lamp where needed. The right-angle bracket can be attached to the mounting surface by drilling and tapping two holes, drilling two clearance holes, or using the two sheet-metal screws. (The mounting template at the top-right corner of this page can be used for spotting the mounting holes.) Then use two of the furnished socket-head cap screws (either the ½" or ¾") to attach the direct-mount base to the tapped holes in the right-angle mounting bracket.

#### Lamp With a C-Clamp or Magnetic Base

Every snake-arm lamp has a direct-mount base at the end of the snake arm. However, if you have a C-clamp or magnetic-base lamp, the C-clamp or magnetic base will be located in a bag inside the box along with two socket-head cap screws and a ⅜" hex key. For these two bases, remove everything from the bag and attach the direct-mount base to the C-clamp or magnetic base with the socket-head cap screws using the hex key. Make sure the cap screws are snug, but be careful not to overtighten them because this could strip out the threads in the C-clamp or magnetic base.

The C-clamp base can be mounted to the edge of a table, bench, or any surface up to 1 7/8" thick. The magnetic base can be used to mount the lamp to any flat, ferrous metal (such as steel or iron). However, if the magnetic base doesn't hold the lamp in place, the metal may not be thick enough or it may not have enough iron in it. For additional holding power, a flat, steel plate can be added to the mounting location.

#### Installation of Lightbulb

With the lamp mounted, install a 100-watt-maximum standard incandescent or equivalent (CFL, LED) screw-in lightbulb (not included). Use only a UL Listed lightbulb that doesn't extend beyond the end of the lampshade.

#### Optional Wire Guard

If you have a wire guard, simply snap the guard onto the front rim of the lampshade.

#### Optional Magnifier Attachment

If you have a magnifier attachment, remove the small nut and screw at the back, gently pull the halves apart, and slide the magnifier attachment up onto the front rim of the lampshade until the bottom of the magnifier attachment is seated against the rim of the lampshade. Once it is in place, replace the small nut and screw at the back of the magnifier attachment and screw in the screw until snug.

#### Warranty

Danray Products LLC warrants that our products will be free from defects in material and workmanship for a period of 12 months from the date of shipment. This warranty does not apply to any product that has been subject to misuse, negligence, or installation not in accordance with Danray Products LLC's instructions.

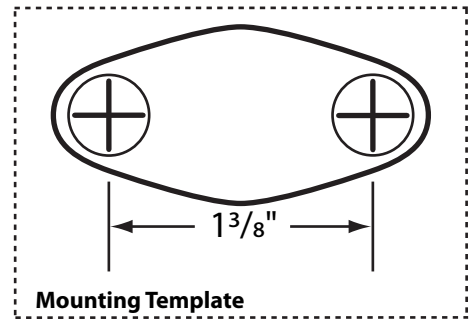

Mounting Template



Direct-Mount Base



Horizontal / Vertical Mounting Brackets



C-Clamp / Magnetic Bases

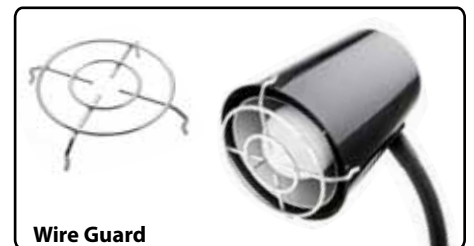

Wire Guard



Magnifier Attachment